

driven
by knowledge



Dipl.-Ing. Frank Pflüger

Regulated 2-stage turbocharging (R2S)

**A new charging system for
commercial diesel engines**

Academy



Regulated Two-Stage Turbocharging - 3K-Warner's New Charging System for Commercial Diesel Engines

Dipl.-Ing. Frank Pflüger, 3K-Warner Turbosystems GmbH

1. Demands on future commercial diesel engines

The development objectives of future commercial diesel engines with regard to thermodynamics and operational reliability are in most cases similar:

- Increase the engine's rated power and/or power-to-weight ratio.
- Make available a very high maximum torque at very low engine speeds and over a wide speed range. This allows, in connection with a suitably matched drive train, reduced engine speeds and, as a result, lower fuel consumption and noise levels.
- Further improvement of the transient response of the engine and hence of the launch characteristics of the vehicle.
- Simultaneously, specific fuel consumption and end user operating costs must be reduced, while maintaining emissions and noise within the prescribed limits (EURO III, EURO IV, etc.).

The development objectives regarding the engine's thermodynamics and operational reliability are therefore the basis for the requirements to be fulfilled by the charging system.

2. Requirements to be fulfilled by future charging systems

The requested higher engine power and a higher brake mean effective pressure require more fuel to be injected into the cylinder and, therefore, an increased air mass flow, i.e. boost pressure. At low engine speeds particularly, it would be preferred to increase also the air/fuel ratio λ_v . An improved λ_v , mixture and combustion would allow fuel consumption and emissions values, especially particulate emissions, to be significantly lowered in this area.

The most important requirements to be met by the charging system are therefore the following:

Make available overproportionately more air, i.e. very high boost pressure, particularly at low engine speeds to obtain the requested λ_v values. High boost pressures at low engine speeds improve the engine's accelerating behaviour, reduce exhaust smoke and allow relatively early high mean effective pressures (intransient). Additionally, the boost pressure must also be increased in the upper speed range to ensure that even higher engine performance - at an even lower rated speed - is realized with low fuel consumption and emissions.

These requirements make a highly developed charging system a necessity.

The desired increased air mass flow for the rated power point basically requires a larger turbocharger to ensure high efficiency at greater air and exhaust gas mass flows. The wish for an overproportionately high air mass flow, i. e. boost pressure, at low engine speeds means however, that the turbine and compressor must be relatively small. The ideal solution would be a combination of both!

To meet these requirements, BorgWarner Turbo Systems has developed the regulated 2-stage turbocharging system. The design of this advanced, electronically controlled charging

system corresponds closely to such an ideal case and accordingly has great potential to fulfill the stated goals.

3. Design and operation of a regulated 2-stage turbocharging system

In the regulated 2-stage turbocharging system, two differently sized turbochargers are positioned in series with bypass control and, ideally, a second charge air cooler (figure 1).

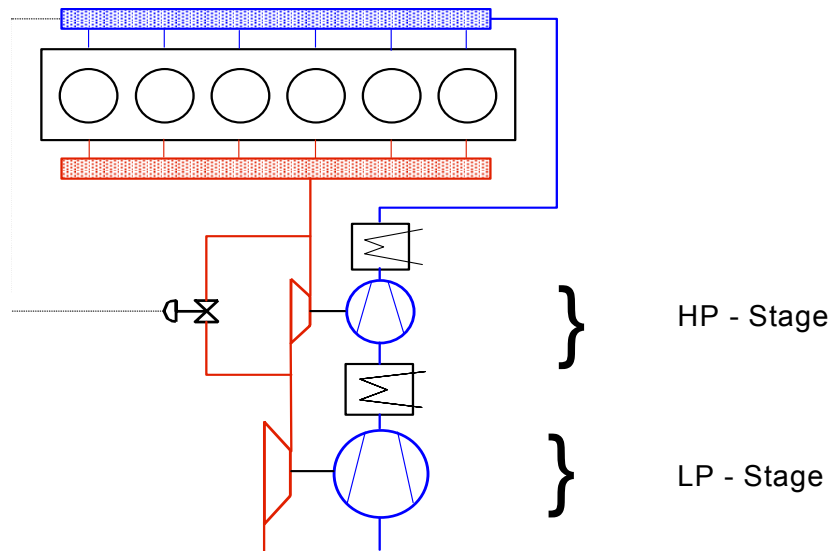

Figure 1: Schematic of regulated 2-stage turbocharging

The exhaust gas mass flow coming from the cylinders first flows into the exhaust gas manifold. From here, either the entire exhaust gas mass flow is expanded through the high pressure turbine (HP) or a part of the mass flow is conducted through the bypass. The entire exhaust gas mass flow then passes again through the low pressure (LP) turbine arranged downstream.

The intake air mass flow is first precompressed through the low pressure stage and, ideally, intercooled. Further compression and charge air cooling takes place in the high pressure stage. As a result of the precompression, the relatively small HP compressor operates at a higher pressure level, so that the required air mass flow throughput can be obtained. At low engine speeds, i. e. low exhaust gas mass flows, the bypass remains closed and the entire exhaust gas expands through the HP turbine. This results in a very quick and high boost pressure rise. With increased engine speed, the bypass valve is opened, progressively shifting more of the expansion work to the LP turbine.

Therefore, the regulated 2-stage turbocharging system allows a stepless, variable matching of the turbine and compressor side to the engine's operational requirements.

Figure 2 shows a possible design of BorgWarner's regulated 2-stage turbocharging system. This compact design is a combination of efficient K-Range standard turbochargers. As HP and LP stage load is relatively low, cost-efficient production turbochargers with a long life time and high reliability can be used.

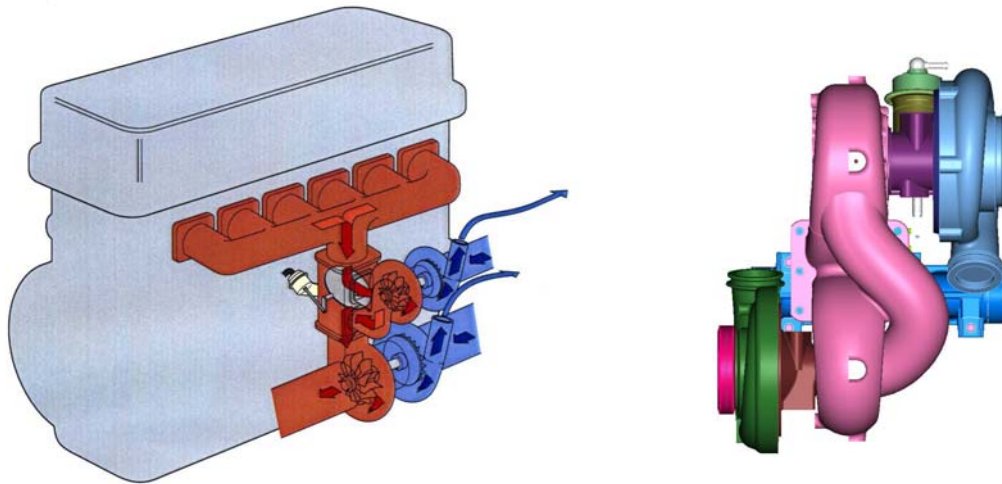

Figure 2: Design of BorgWarner's regulated 2-stage turbocharging system

4. Measured results with a 12-litre commercial diesel engine

The results obtained with a modern 12-litre, 6-cylinder commercial diesel engine clearly show the improved performance of the regulated 2-stage turbocharging system relative to the current non-regulated, single-stage turbocharging.

For this specific case of application, production turbocharger components were matched, through engine process computation, taking into account the following conditions:

- Reduction of the engine's rated speed from 2000 rpm to 1800 rpm (for noise and fuel consumption reasons)
- Observation of the permissible cylinder pressure and exhaust gas temperature
- Use of an undersized charge air cooler for space reasons
- Observation of the valid emissions values

4.1 Full-load results

Figure 3 shows typical boost pressure curves obtained with both charging systems. Compared with single-stage turbocharging, the boost pressure rise is significantly higher with this new charging system, particularly at low engine speeds.

Already at 800 rpm engine speed, the available boost pressure increases from approx. 1350 mbar to around 2400 mbar (absolute pressure). From 1100 rpm onward, boost pressure is limited to 3000 mbar through the bypass control to ensure the permissible peak cylinder pressure for the test engine is not exceeded.

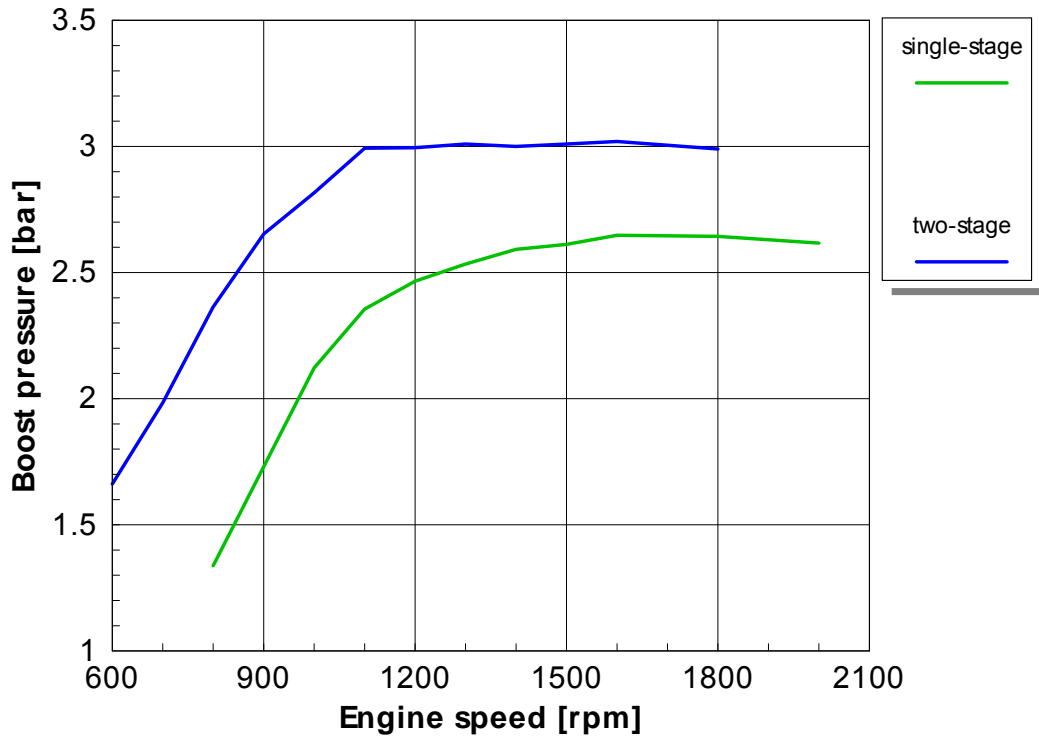

Figure 3: Boost pressure comparison

Figure 4 shows the comparison of the air/fuel ratios λ_v with single- and two-stage turbocharging, at full load versus the engine speed. The significantly improved air supply with a regulated 2-stage turbocharging system is clearly evident. The effect of the boost pressure control is evident above 1400 rpm. The high boost pressures below 1400 rpm result in a lower exhaust gas temperature and hence reduced thermal load of the engine. At the rated power point, the exhaust gas temperature with regulated 2-stage turbocharging is not higher than the peak value with standard turbocharging. The improvements with regard to smoke number and fuel consumption are even more significant.

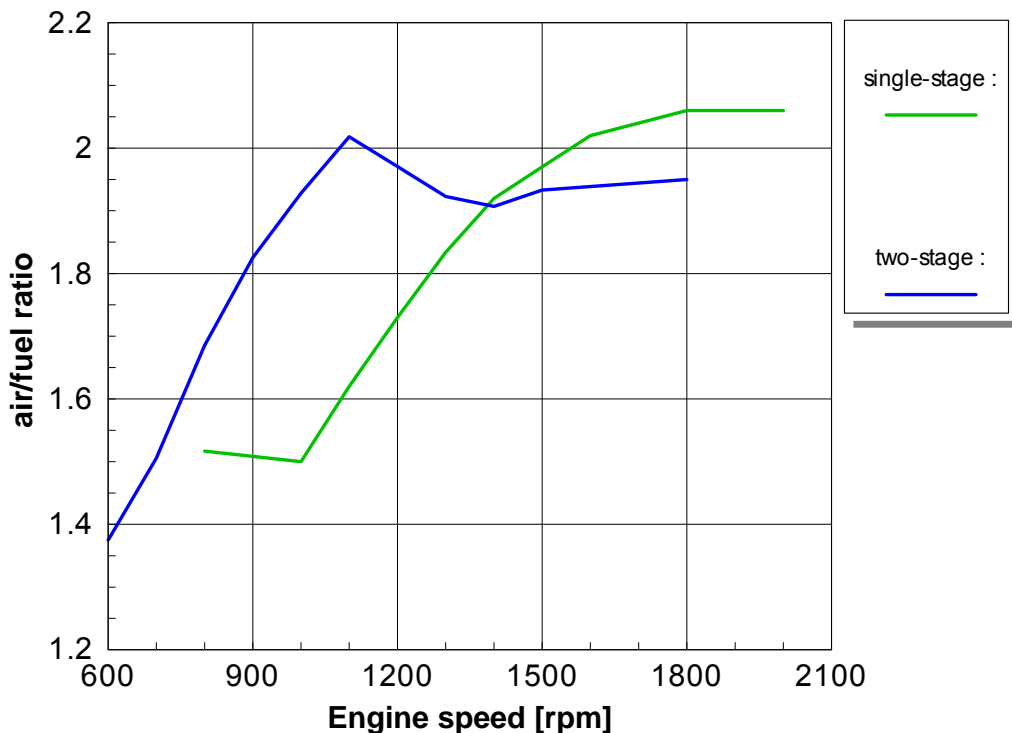

Figure 4: Comparison of air/fuel ratios λ_v

Figure 5 shows the corresponding Bosch smoke number curves of both systems. In the upper speed range (from 1400 rpm onward), the effect of λ_v on the smoke number is very low. Whereas the air/fuel ratio of both systems varies between $\lambda_v = 1,90$ and $2,05$, the smoke number remains constant = $0,4$. In the low to medium speed range, smoke numbers are significantly reduced with the 2-stage turbocharging. At 1100 rpm, the smoke number can be halved, from $SN = 0,6$ to $SN = 0,3$. At 800 rpm, the smoke number is reduced by 80%, from $SN > 2,0$ to $SN = 0,4$.

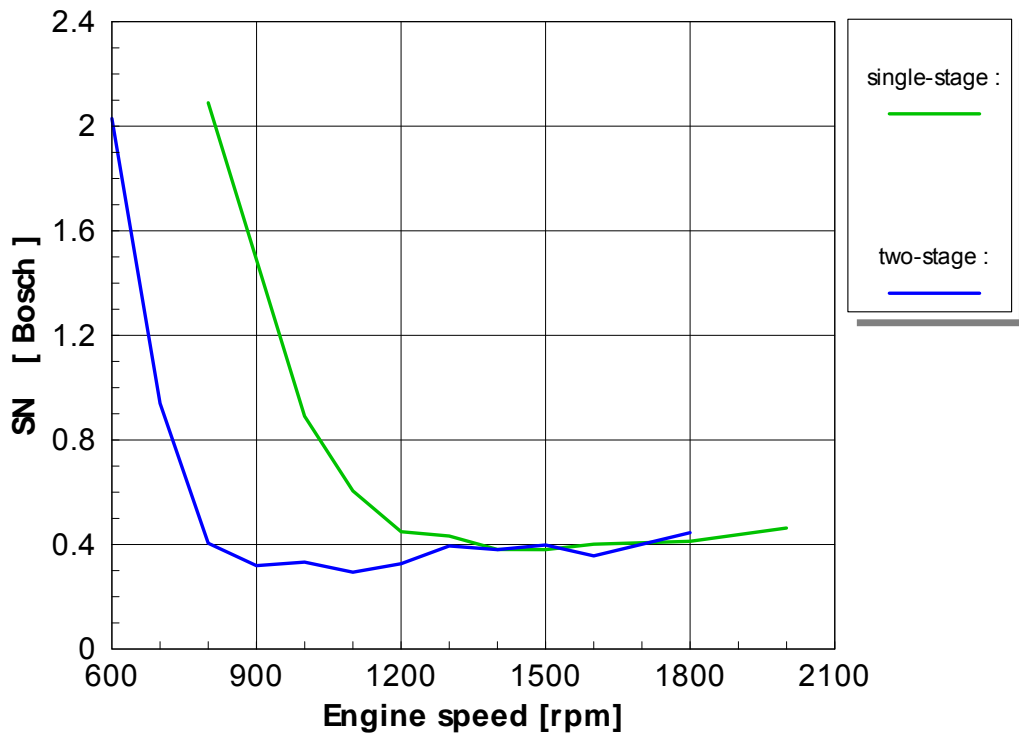

Figure 5: Smoke number comparison

It must be noted that the production test engine already operates near the allowable limit of peak cylinder pressure. Limiting the boost pressure to 3000 mbar was insufficient to remain below the peak cylinder pressure limit. For this reason, the start of injection with 2-stage turbocharging has been retarded a few degrees of crank angle, so that the peak cylinder pressure always remains below the limit value, even at very high boost pressures.

A retarded start of injection has advantages and disadvantages. As a result of the relatively late injection start, peak pressures are still within limits and the pressure rise rate is lower (combustion noise), despite the high boost pressure. But a retarded combustion start is prejudicial for optimal fuel consumption. The following will show that excellent fuel consumption figures can be obtained with BorgWarner's regulated two-stage turbocharging system, despite the relatively late start of injection.

Both engine versions use different transmission ratios and have different rated speeds. To relate different transmission ratios, a representation versus the relative speed is recommended, i.e. a relative comparison of both charging and drive concepts.

Figure 6 shows the brake mean effective pressure curve BMEP versus the relative speed. This speed is the relation between the relative and the rated speed of the engine. The rated speed with single-stage turbocharging is 2000 rpm, with the 2-stage charging system it has been reduced to 1800 rpm.

With regulated two-stage turbocharging, the rated power was increased, in the present case by approx. 10% to 327 kW at 1800 rpm. 298 kW peak power is available already at 80% of the reduced rated speed (1400 rpm). Furthermore, the brake mean effective pressure and hence torque increases (Δ BMEP and/or Δ BRTQ) are significantly higher at low engine speeds.

The measured BMEP curve reflects the engine's ignition pressure limit. Process computations show regulated two-stage turbocharging would easily allow a significantly higher torque rise, as shown by the dot-dash line in figure 6. To this effect however, the engine should be designed for higher ignition pressures.

Figure 7 shows the corresponding curve of the effective specific fuel consumption b_e versus the relative engine speed, related to the best full-load value achieved with production charging systems (corresponds to $b_e = 100\%$). In addition to the higher power output, BorgWarner's regulated 2-stage turbocharging ensures fuel consumption economies of 2 - 6.5% over a wide range even with the retarded injection.

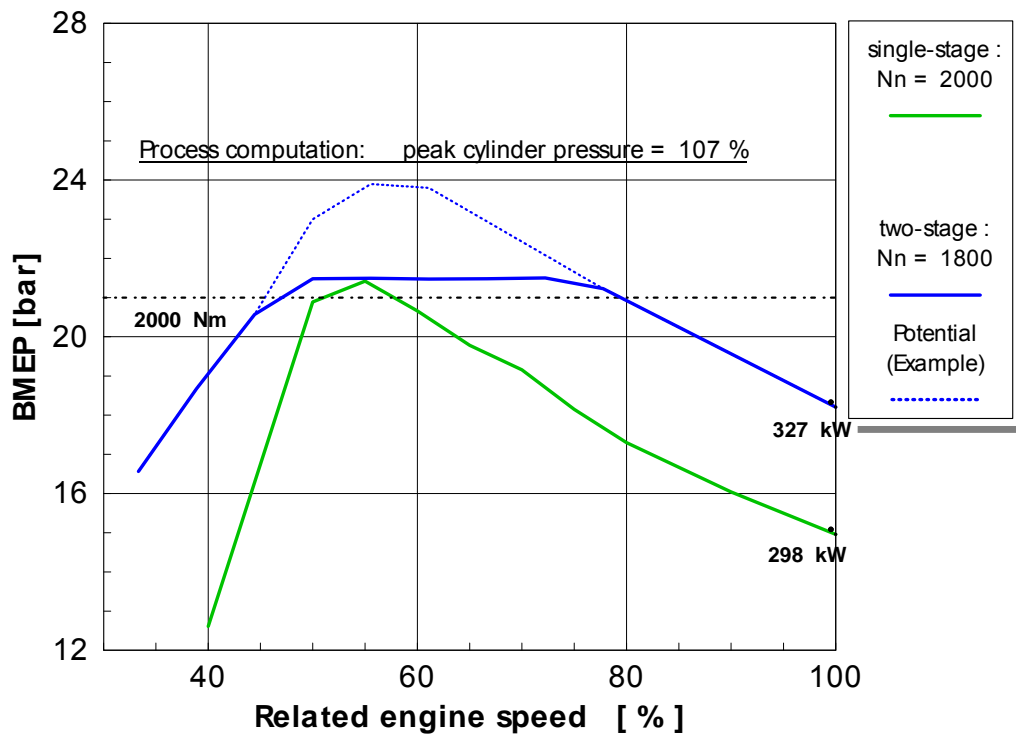

Figure 6: Relative BMEP curve comparison

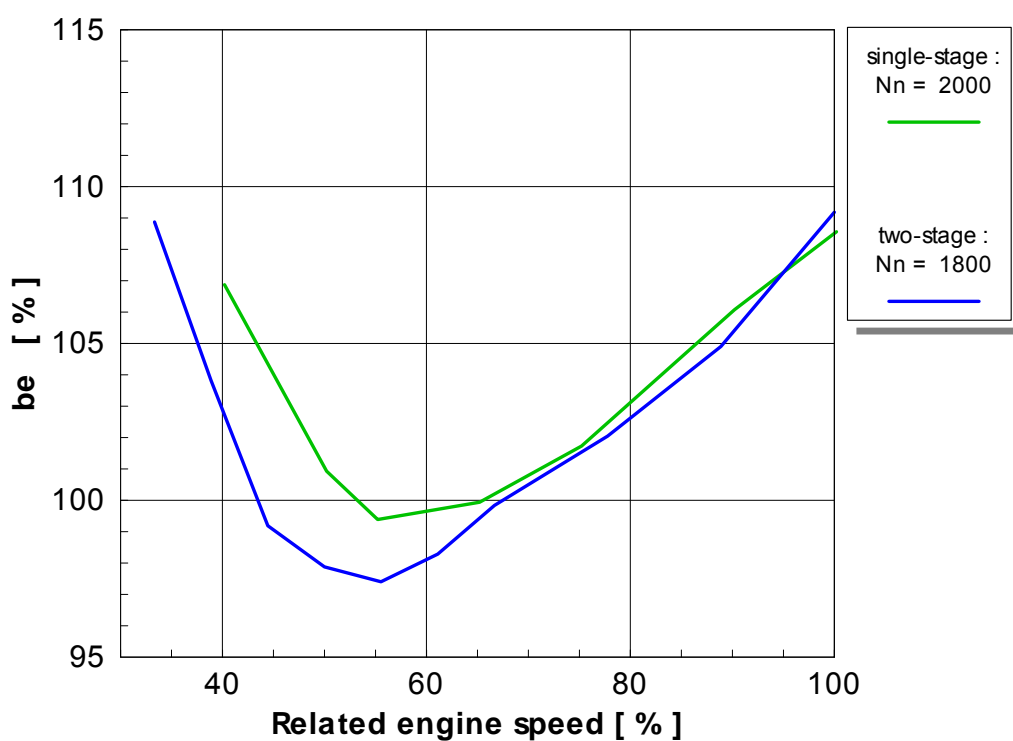

Figure 7: Relative b_e curve comparison

So far, only the engine's full-load characteristics have been considered. For the full-load boost pressure limitation, regulated two-stage turbocharging only requires a common, purely pneumatic boost pressure control. After a certain boost pressure is reached, a part of the exhaust gas mass flow is conducted through the bypass and does not pass through the HP turbine. From a certain engine speed onward, the boost pressure does not increase. When implementing the regulated two-stage turbocharging, a flexible boost pressure control would be preferred, allowing a free optimization also at part load of the engine.

As already state-of-the-art in passenger cars, electronic map control allows the turbine to be bypassed at part load of the engine. To this effect, a nominal boost pressure map is stored in the electronic diesel control (EDC). The additional component needed is a pulse modulated valve. Therefore, the required additional costs are low if EDC is available, as in the considered case. The following engine maps show the resulting potential for BorgWarner's regulated two-stage turbocharging.

4.2 Part-load results

Figure 8a shows the λ_v map for single-stage turbocharging with series injection. The lines of constant fuel/air ratio are plotted versus the brake mean effective pressure and engine speed. λ_v values decrease from yellow to red, i. e. become increasingly critical. This graphic shows that standard charging systems do not allow higher brake mean effective pressures to be achieved at low engine speeds, because λ_v decreases too much and results in unacceptable smoke numbers.

Figure 8b shows in comparison the λ_v engine map with regulated two-stage turbocharging. The boost pressure chosen for every operating point ensures optimum fuel consumption. When compared with standard turbocharging, the red critical areas are significantly smaller and shifted to the left to those brake mean effective pressure areas which formerly could not be achieved.

With 12,5 bar brake mean effective pressure (BMEP) at 800 rpm, λ_v increases from approx. 1,45 to $\lambda_v = 1,9$, i. e. air excess increases by $\Delta \lambda_v = 25\%$. Even at a BMEP increase to 20,5 bar (DBMEP = + 65%), the fuel/air ratio at this low engine speed is with $\lambda_v = 1,7$ still significantly higher than the initial value. With regulated 2-stage turbocharging, a λ_v value of

1,8 is achieved from 850 rpm full-load speed onward, against 1300 rpm in the single-stage case. The significantly improved air supply with BorgWarner's two-stage turbocharging in the important operating range of low speeds and high brake mean effective pressures becomes herewith evident.

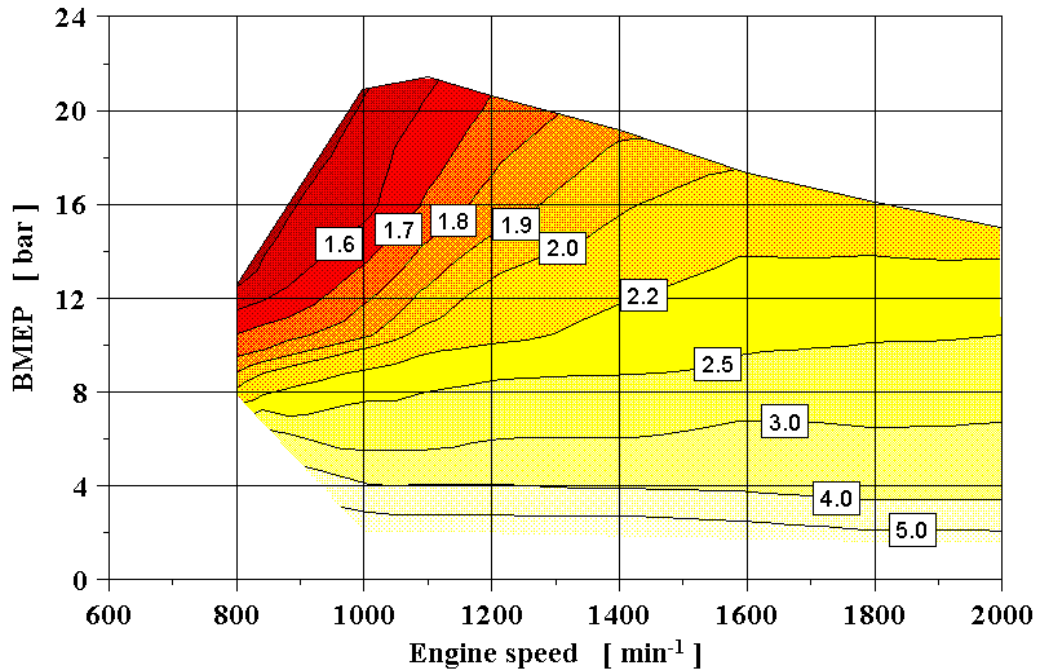

Figure 8a: λ_v map with single-stage turbocharging

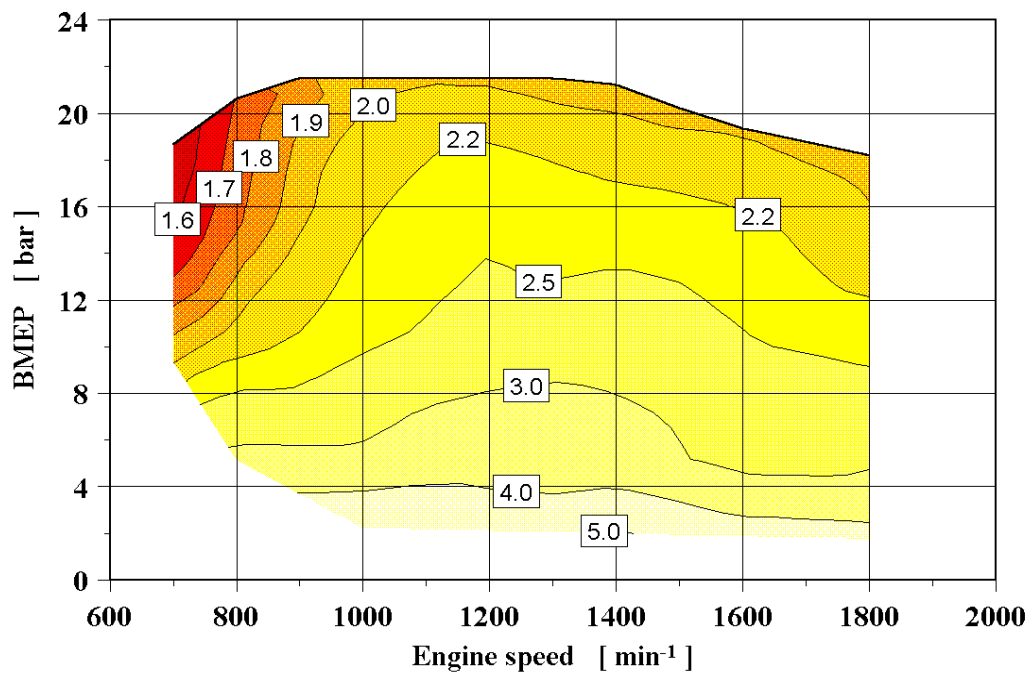

Figure 8b: λ_v map with regulated two-stage turbocharging

High λ_v values have a positive effect on the smoke number SN. Figure 9a shows the Bosch smoke number curve versus the engine load and speed with single-stage production turbocharging. The highest smoke numbers occur at low engine speeds and high loads. The green map areas are relatively uncritical. Smoke numbers here are below SN = 0,4. In the red map area, the smoke number exceeds 1,0 and the peak value amounts to SN = 2,0 in the dark map area.

With two-stage turbocharging, figure 9b, the former peak smoke numbers completely disappear. From approx. 800 rpm onward, smoke number values are generally below SN = 1,0. In the entire lower map range, the smoke number SN is halved, on an average. In the upper quarter of the speed range smoke numbers are equal low, as the fuel/air ratio λ_v in both cases is adequate.

In connection with a retarded (basically NOx reducing) injection start, regulated two-stage turbocharging allows a significant overall smoke number SN reduction with expected reduced particulate emissions.

With two-stage turbocharging, boost pressure can be freely varied over a wide range to ensure optimum matching to the engine's air requirements. This can also be used with regard to NOx emissions. Thus, regulated two-stage turbocharging offers an additional potential to reduce NOx emissions.

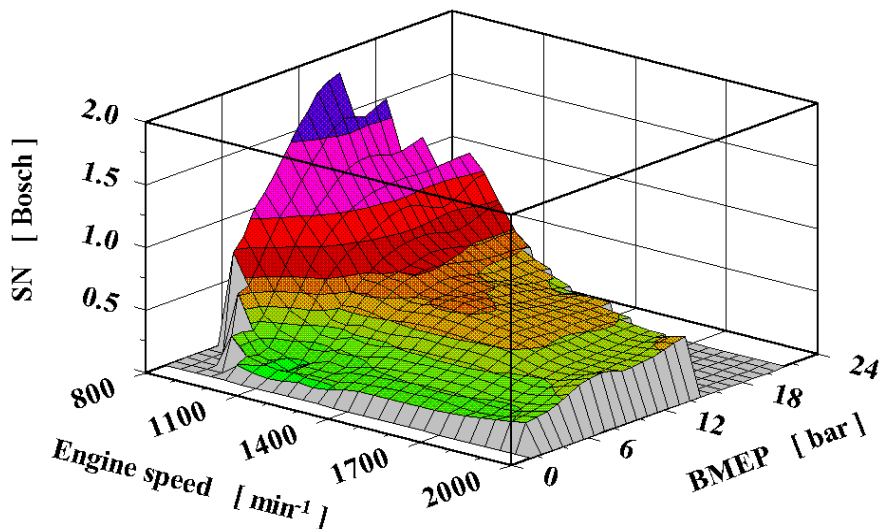

Figure 9a: SN map with single-stage turbocharging

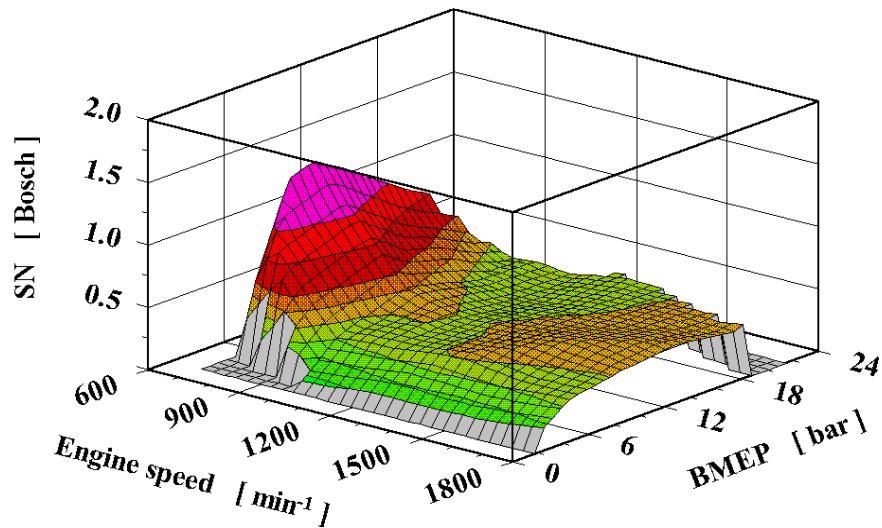

Figure 9b: SN map with regulated two-stage turbocharging

Figure 10a shows the fuel consumption map of the engine with production injection and single-stage turbocharging. The BMEP is plotted versus the relative engine speed. 40% of the relative engine speed means here 800 rpm, 100% of the rated speed is 2000 rpm. Plotted are islands of constant specific fuel consumption b_e , always referred to the best fuel consumption at the full-load line (100%), and lines of constant engine power: 100 kW and 200 kW. The island with the lowest consumption is that with a value of 101%, referred to the best full-load value. The highest specific fuel consumption is shown by the 180% island.

Figure 10b shows in comparison the fuel consumption map of the engine with regulated two-stage turbocharging. 40% of the relative engine speed in this case is a speed of 720 rpm, 100% of the rated speed is 1800 rpm. Compared to production applications, the injection start for the ignition pressure limitation has been retarded several degrees of crank-shaft angle, without taking into account fuel consumption disadvantages, particularly at part load. The boost pressure chosen for every operating point ensures optimum fuel consumption. Plotted are lines of constant specific fuel consumption b_e , and lines of constant engine power (additionally: 300 kW).

When compared with production applications, the 180% fuel consumption island completely disappears with regulated two-stage turbocharging. The main operating range in commercial diesels lies in a new 101% fuel consumption island (again referred to the best full-load consumption with standard turbocharging). In this area, fuel consumption improvements with BorgWarner's regulated two-stage turbocharging amount to approximately $\Delta b_e = 6$ to 8 g/kWh , on an average.

The fuel consumption figure at constant 100 kW engine power and approx. 70% engine rated power is an important point used in practice for comparisons: the specific fuel consumption b_e with single-stage series turbocharging is approx. 108%, referred to the best full-load consumption. With regulated 2-stage turbocharging, the engine's fuel consumption at this operating point can be reduced to 101%. The fuel consumption benefit amounts here to approx. 7%.

Finally, the full-load boost pressure curve with 2-stage turbocharging (see figure 3) clearly shows that not only the transient, but also the intransient response is significantly improved when compared with single-stage turbocharging.

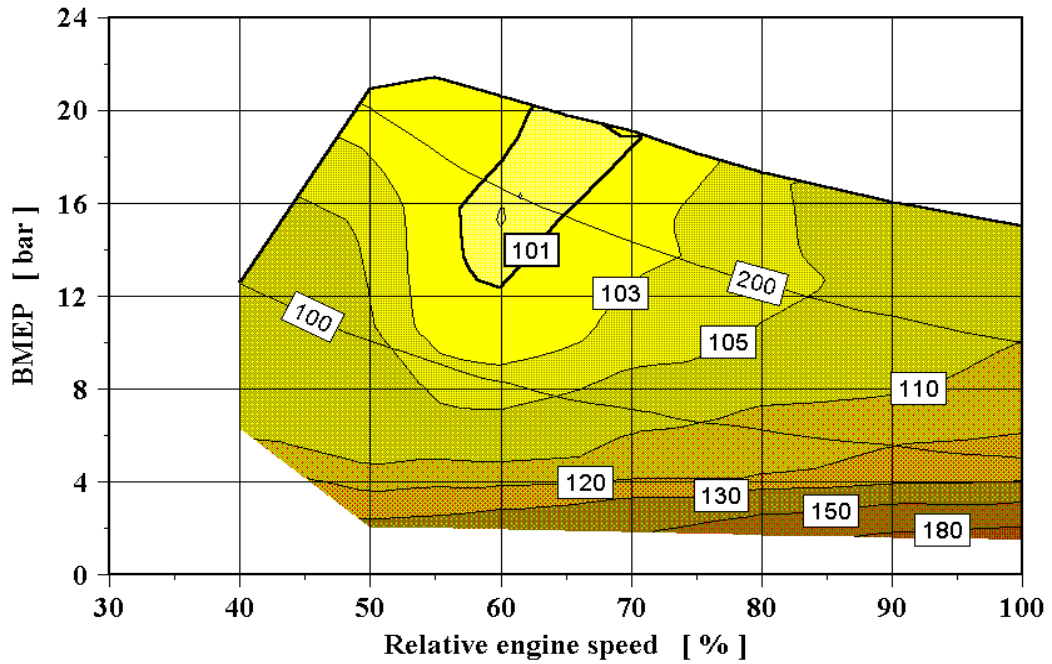

Figure 10a: b_e map with single-stage series turbocharging

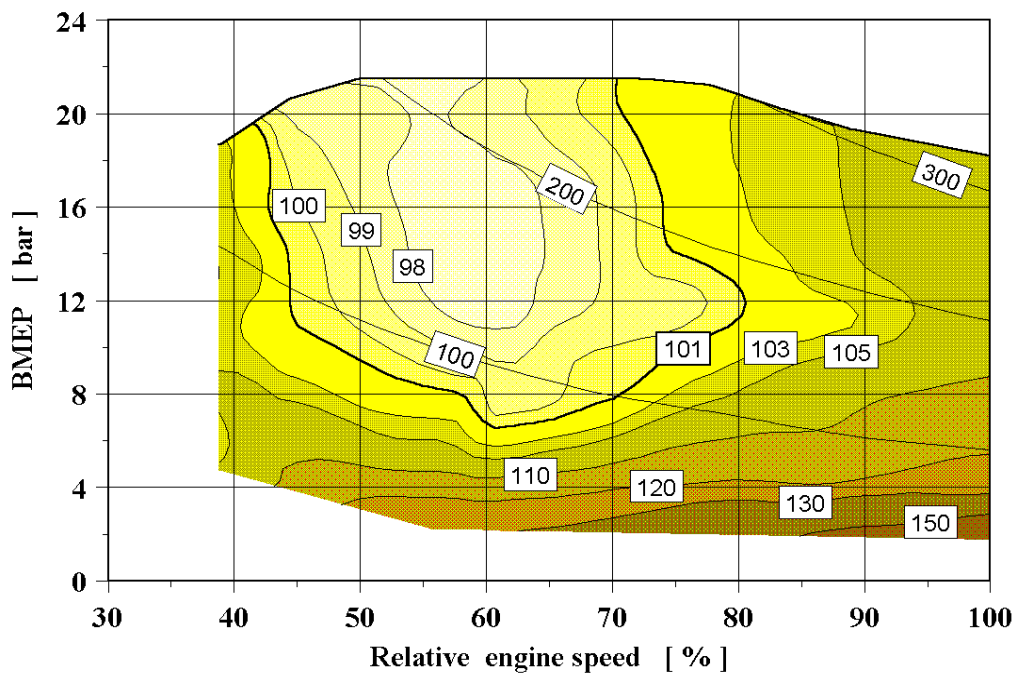

Figure 10b: b_e map with regulated two-stage turbocharging

5. Synopsis

The basic development objectives for future turbocharged commercial diesel engines require further developed charging systems.

The design of such charging systems with regard to the engine's rated power on the one hand, and the transient response and the maximum torque range on the other hand, results in a target conflict. For the rated power point, the required turbocharger must be relatively large. The wish for a very high boost pressure at low engine speeds means however, that the turbine and compressor must be relatively small. The ideal solution is a combination of both.

To solve this conflicting target, BorgWarner Turbo Systems has developed the regulated two-stage turbocharging system. This system meets the requirements of such an ideal design and allows a stepless, variable matching of the turbine and compressor sides for each operating point of the engine.

The results obtained with a modern 12-litre commercial diesel engine show the exceptional potential of this new charging systems. The achieved objectives are proven by the results obtained at full load and part load. Transient response advantages are compared with other turbocharger systems.

Major benefits of BorgWarner's regulated two-stage turbocharging are:

- high torque at lowest engine speeds
- rated power increase and, additionally, rated speed reduction
- improved boost pressure characteristic
- reduced fuel consumption
- reduced smoke number
- potential to lower NOx emissions
- improved transient response
- well-tested components with long life time and reliability

With this new charging system, BorgWarner Turbo Systems provides engine manufacturers with another powerful solution for charging systems for future commercial diesel engine generations which meet highest demands with regard to power, fuel consumption and environmental friendliness.

BorgWarner Turbo Systems is prepared to draw up package solutions with interested engine manufacturers. These solutions include the selection of the corresponding turbochargers and the optimized arrangement of the turbochargers and control components in the available installation space.

BorgWarner Turbo Systems
Worldwide Headquarters GmbH
Mannheimer Strasse 88
67292 Kirchheimbolanden / Germany
Phone: ++49 (0)6352 75 33 0
Fax: ++49 (0)6352 75 33 99

3K-Warner Turbosystems GmbH
Mannheimer Strasse 85/87
67292 Kirchheimbolanden / Germany
Phone: ++49 (0)6352 403 0
Fax: ++49 (0)6352 403 1866

BorgWarner Turbo Systems Ltd.
Euroway Industrial Estate
Bradford BD4 6SE
West Yorkshire / UK
Phone: ++44 1274 684 915
Fax: ++44 1274 689 671

BorgWarner Turbo Systems
PO Box 15075
Asheville, NC 28813/USA
Phone: 001 828 684 4000
Fax: 001 828 684 4114

BorgWarner Automotive Brasil Ltda.
Estrada da Rhodia Km 15
P.O. Box 6540
13084-970 Campinas-SP / Brasil
Phone: ++55 19 3787 5700
Fax: ++55 19 3787 5701

Hitachi Warner Turbo Systems Ltd.
3085-5 Higashi Ishikawa Saikouchi, Hitachinaka-shi
Ibaraki-ken
312-0052, Japan
Phone: +81 (0) 29-276-9388
Fax: +81 (0) 29-276-9397

www.turbos.bwauto.com

